

## Kesim Ölçüleri Cutting Measures

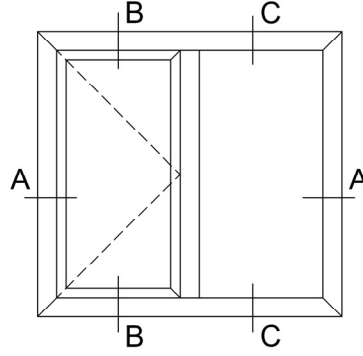

B-B Kesiti  
Section B-B

C-C Kesiti  
Section C-C

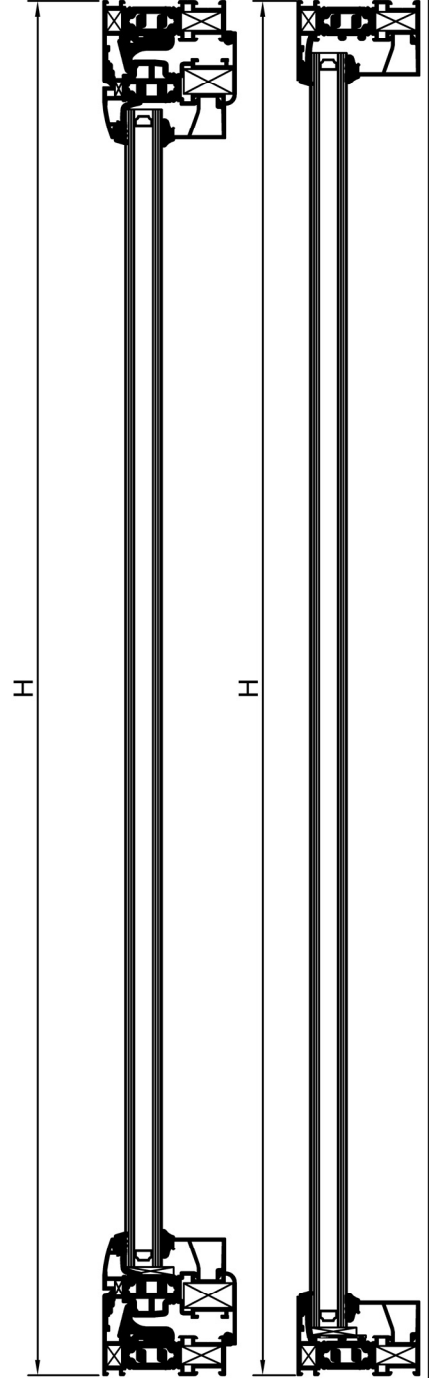

Profilin adı Profile Name	Kodu Code	Sembol Symbol	Adet Quantity	Kesim Cutting
Dar Kasa Profili Frame Profile	80ST10		2	
			2	
Dar Kanat Profili Vent Profile	80ST25		2	
			2	
Dar Orta Kayıt Profili Transom-Mullion Profile	80ST30		1	
Cam Çıtası Profili Glazing Bead	09-3115		2	
			2	
Cam Çıtası Profili Glazing Bead	09-3117		2	
			2	

\*\* Not: Cam Çıtası Profillerinin ölçüleri preslenmiş kasa veya kanat üzerinden belirlenecektir.  
The mesasures of Glazing Bead will be determinate on pressed Frame and Vent.

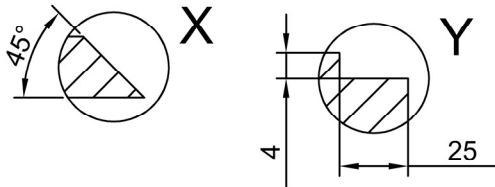

Ölçek : 1/5  
Scale : 1/5

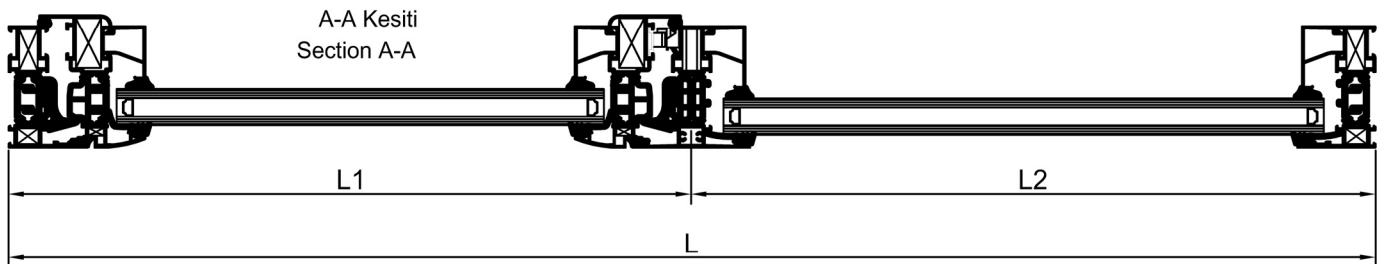

# ST 80

## Kesim Ölçüleri Cutting Measures

Profilin adı Profile Name	Kodu Code	Sembol Symbol	Adet Quantity	Kesim Cutting
Geniş Kasa Profili Frame Profile	80ST11		1	L
			2	H
Kanat Profili Vent Profile	80ST24		1	L <sub>1</sub> -78,5
			1	L <sub>2</sub> -78,5
			3	H <sub>2</sub> -63
Geniş Orta Kayıt Profili Transom-Mullion Profile	80ST31		1	L-92
Adaptör Profili Adapter Profile	80ST43		1	L-92
			2	H <sub>2</sub> -33
Kanat Profili Vent Profile	80ST23		1	H <sub>2</sub> -78
Etek Profili Bottom Rail Profile	80ST33		1	L <sub>1</sub> -217
			1	L <sub>2</sub> -192
Cam Çıtası Profili Glazing Bead	09-3117		2	**
			2	**
			2	**
			2	**
			4	**

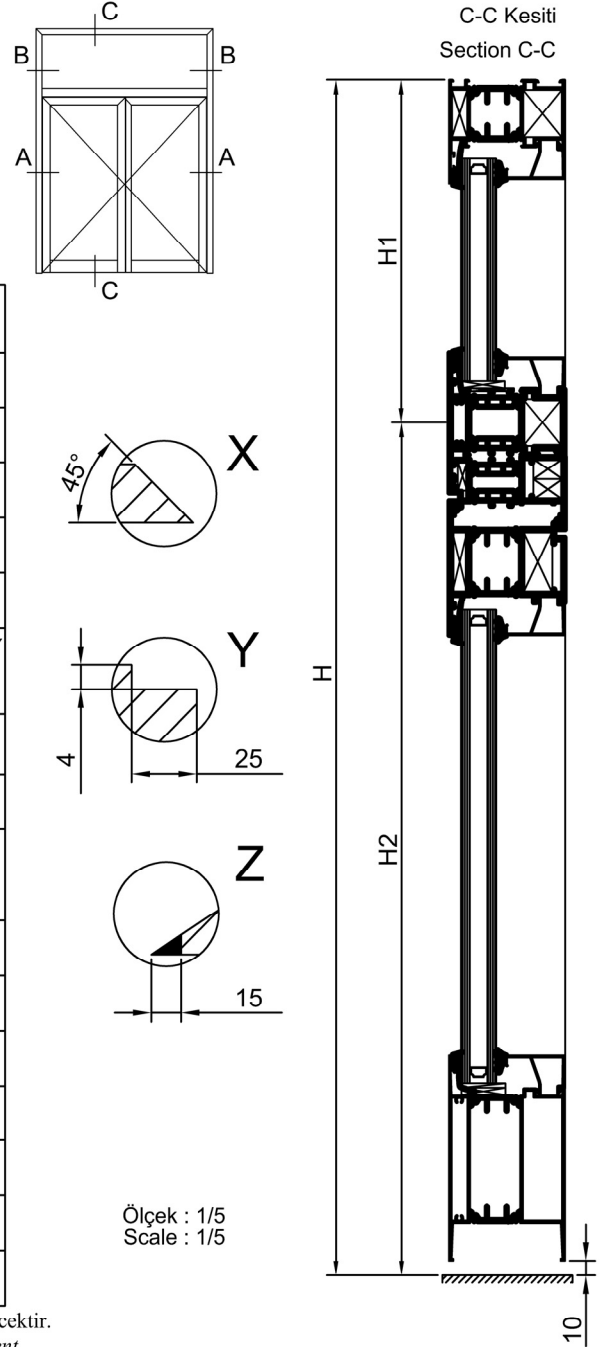

\*\* Not: Cam Çıtası Profillerinin ölçüleri preslenmiş kasa veya kanat üzerinden belirlenecektir.  
The measures of Glazing Bead will be determinate on pressed Frame and Vent.

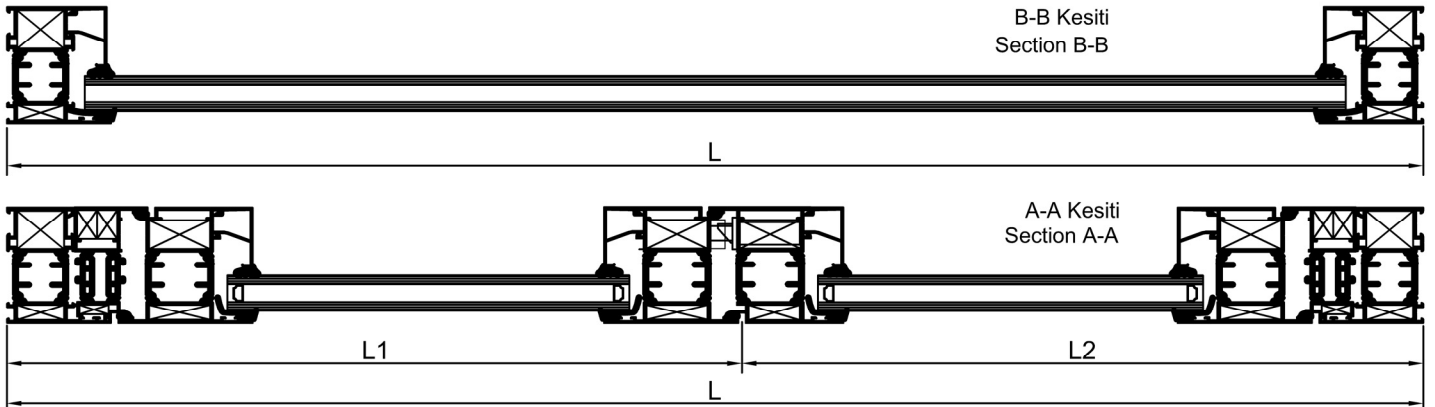

# ST 80

## Kesim Ölçüleri Cutting Measures

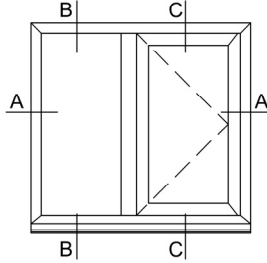

B-B Kesiti  
Section B-B

C-C K  
Sector

Profilin adı Profile Name	Kodu Code	Sembol Symbol	Adet Quantity	Kesim Cutting
Dar Kasa Profili Frame Profile	80ST10		2	
			2	
Dışa Açılır Pencere Kanat Profili Vent Profile	80ST61		2	
			2	
Dar Orta Kayıt Profili Frame Profile	80ST30		1	
Denizlik Profili Sill profile	80ST45		1	
Cam Çıtası Profili Glazing Bead	09-3120		2	
			2	
			2	
			2	

\*\* Not: Cam Çıtası Profillerinin ölçüleri preslenmiş kasa veya kanat üzerinden belirlenecektir.  
The mesasures of Glazing Bead will be determinate on pressed Frame and Vent.

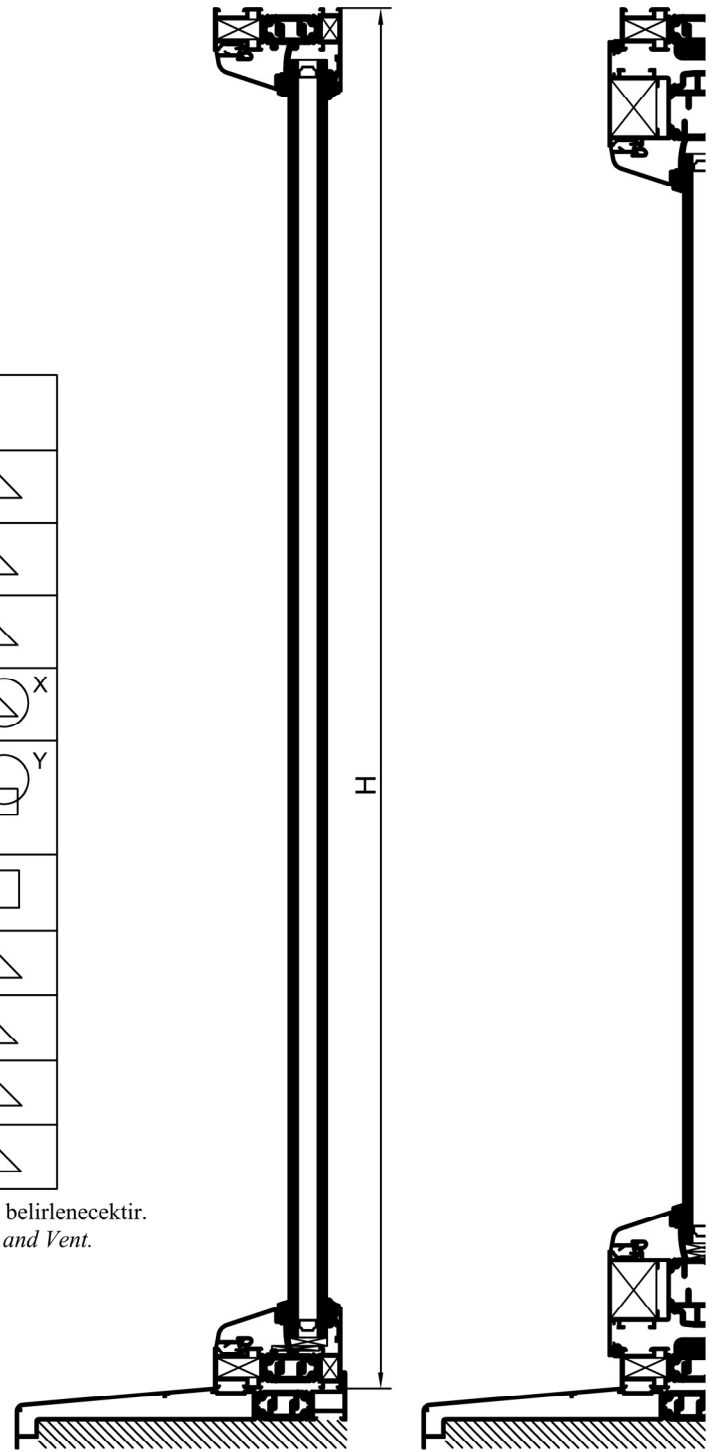
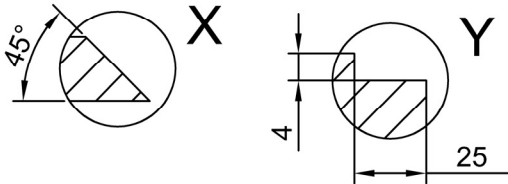

Ölçek : 1/5  
Scale : 1/5

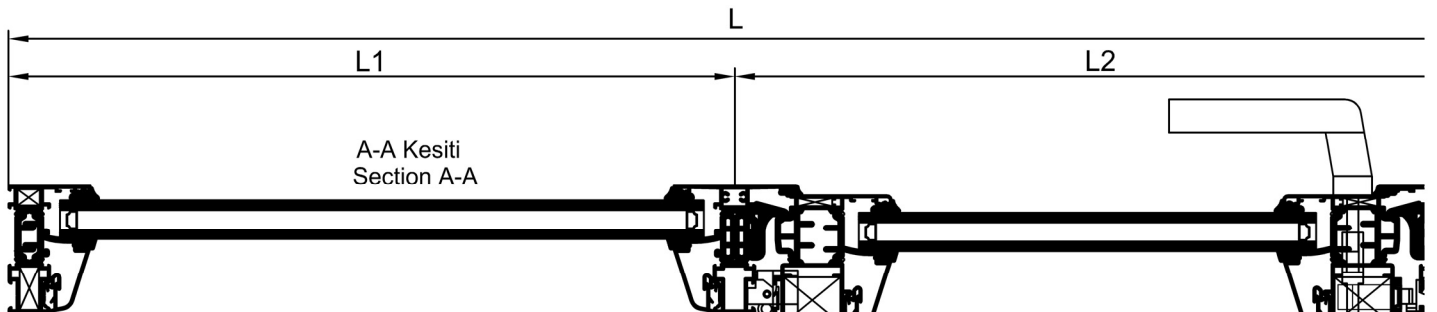

# ST 80

## Kesim Ölçüleri Cutting Measures

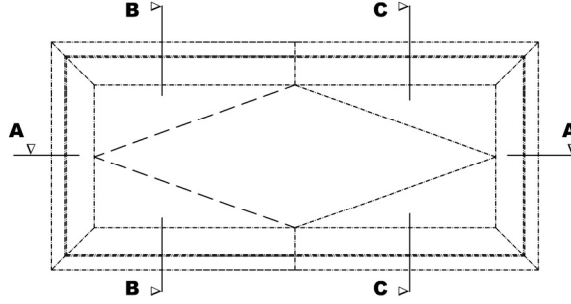

Section B-B  
B-B Kesiti

Section C-C  
C-C Kesiti

Profilin adı Profile Name	Kodu Code	Sembol Symbol	Adet Quantity	Kesim Cutting
Dar Kasa Profili Frame Profile	80ST10		2	
			2	
Adaptör Profili Vent Profile	80ST49		2	
			2	
			2	
Kanat Profili Vent Profile	80ST26		2	
			2	
Cam Çıtası Profili Glazing Bead	3115		2	
			2	

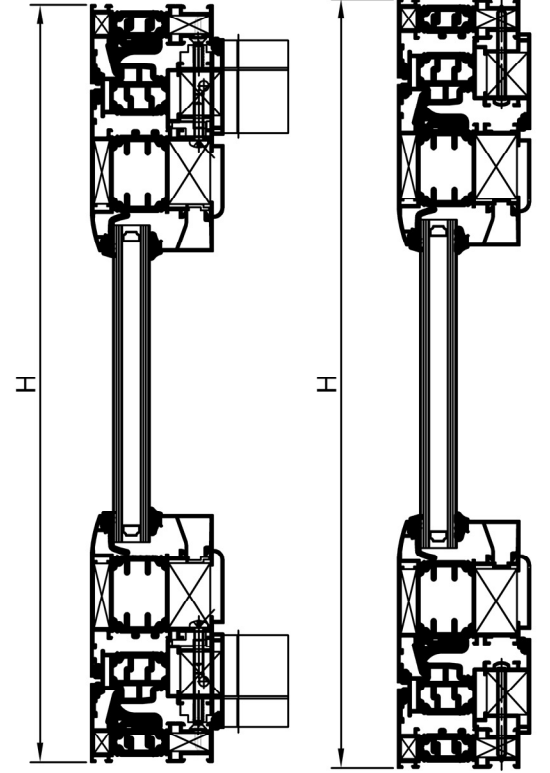

\*\* Not: Cam Çıtası Profillerinin ölçüleri preslenmiş kasa veya kanat üzerinden belirlenecektir.  
The mesasures of Glazing Bead will be determinate on pressed Frame and Vent.

Ölçek : 1/5  
Scale : 1/5

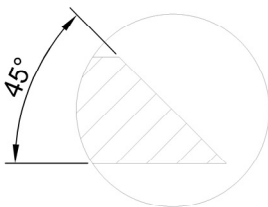

X

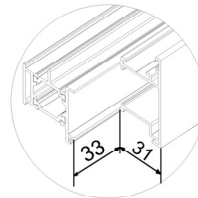

Y

Section A-A  
A-A Kesiti

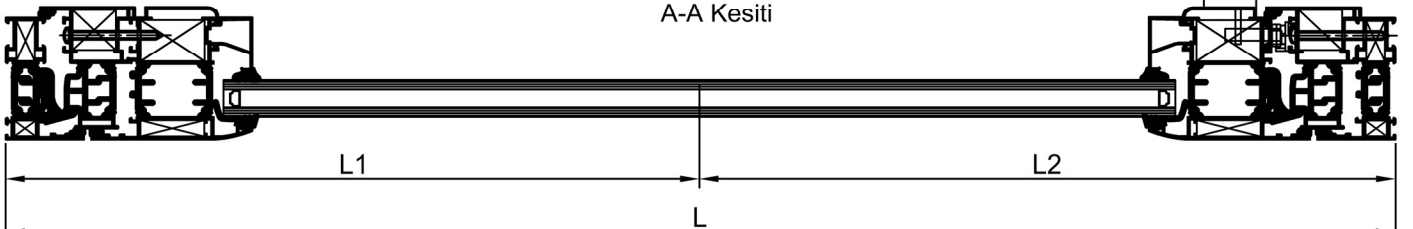

## Kesim Ölçüleri Cutting Measures

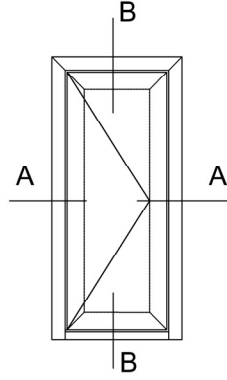

B-B Kesiti  
Section B-B

Profilin adı Profile Name	Kodu Code	Sembol Symbol	Adet Quantity	Kesim Cutting
Kasa Profili Frame Profile	80ST12		1	
			1	
Kanat Profili Vent Profile	80ST62		1	
			1	
Eşik Profili Vent Profile	80ST75		1	
Cam Çıtası Profili Glazing Bead	3111		2	
			2	

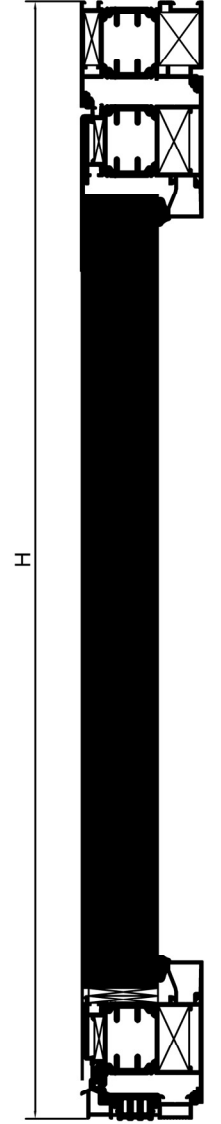
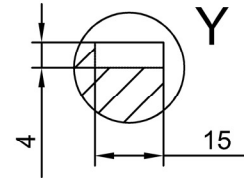
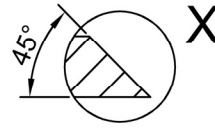

\*\* Not: Cam Çıtası Profillerinin ölçüleri preslenmiş kasa veya kanat üzerinden belirlenecektir.  
The measures of Glazing Bead will be determinate on pressed Frame and Vent.

Ölçek : 1/5  
Scale : 1/5

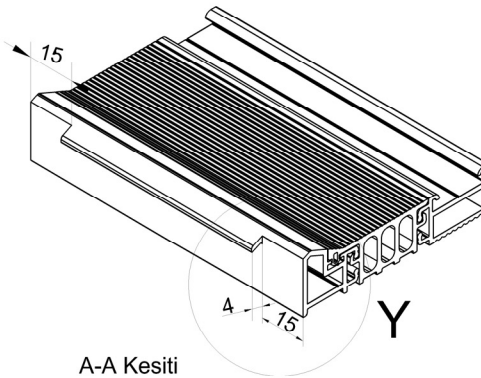

A-A Kesiti  
Section A-A

