

## Kesim Ölçüleri Cutting Measures

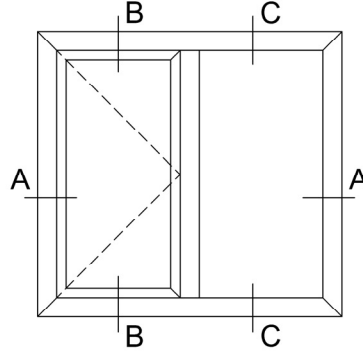

B-B Kesiti  
Section B-B

C-C Kesiti  
Section C-C

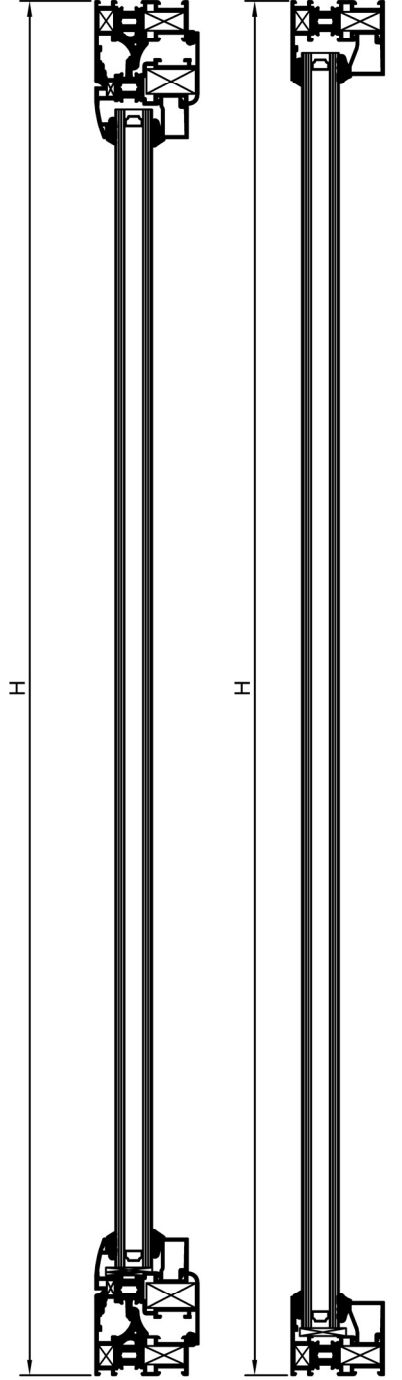

| Profilin adı<br>Profile Name                      | Kodu<br>Code | Sembol<br>Symbol | Adet<br>Quantity | Kesim<br>Cutting |
|---|--------------|------------------|------------------|------------------|
| Dar Kasa Profili<br>Frame Profile                 | 60ST10       |                  | 2                |                  |
|   |              |                  | 2                |                  |
| Dar Kanat Profili<br>Vent Profile                 | 60ST25       |                  | 2                |                  |
|   |              |                  | 2                |                  |
| Dar Orta Kayıt Profili<br>Transom-Mullion Profile | 60ST30       |                  | 1                |                  |
| Cam Çıtası Profili<br>Glazing Bead                | 3109         |                  | 2                |                  |
|   |              |                  | 2                |                  |
| Cam Çıtası Profili<br>Glazing Bead                | 3111         |                  | 2                |                  |
|   |              |                  | 2                |                  |

\*\* Not: Cam Çıtası Profillerinin ölçüleri preslenmiş kasa veya kanat üzerinden belirlenecektir.  
The measures of Glazing Bead will be determinate on pressed Frame and Vent.

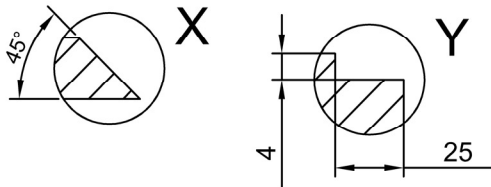

Ölçek : 1/5  
Scale : 1/5

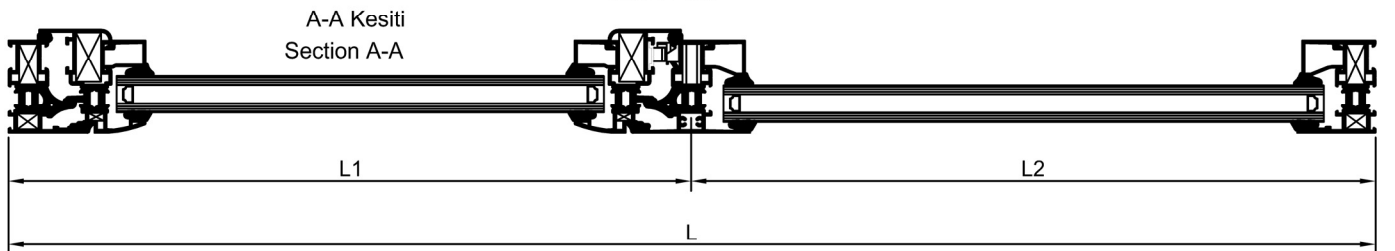

## Kesim Ölçüleri Cutting Measures

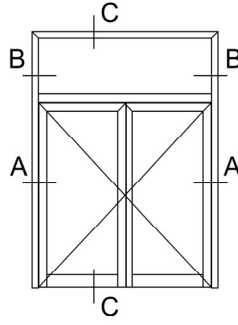

C-C Kesiti  
Section C-C

| Profilin adı<br>Profile Name                        | Kodu<br>Code | Sembol<br>Symbol | Adet<br>Quantity | Kesim<br>Cutting |
|---|--------------|------------------|------------------|------------------|
| Geniş Kasa Profili<br>Frame Profile                 | 60ST11       |                  | 1                |                  |
|   |              |                  | 2                |                  |
| Kanat Profili<br>Vent Profile                       | 60ST24       |                  | 1                |                  |
|   |              |                  | 1                |                  |
|   |              |                  | 3                |                  |
| Geniş Orta Kayıt Profili<br>Transom-Mullion Profile | 60ST31       |                  | 1                |                  |
| Adaptör Profili<br>Adapter Profile                  | 60ST43       |                  | 1                |                  |
|   |              |                  | 2                |                  |
| Kanat Profili<br>Vent Profile                       | 60ST23       |                  | 1                |                  |
| Etek Profili<br>Bottom Rail Profile                 | 60ST33       |                  | 1                |                  |
|   |              |                  | 1                |                  |
| Cam Çıtası Profili<br>Glazing Bead                  | 3111         |                  | 2                | **               |
|   |              |                  | 2                | **               |
|   |              |                  | 2                | **               |
|   |              |                  | 2                | **               |
|   |              |                  | 4                | **               |

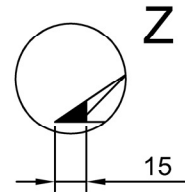
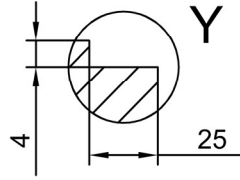
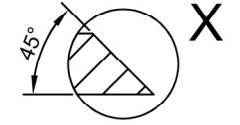

Ölçek : 1/5  
Scale : 1/5

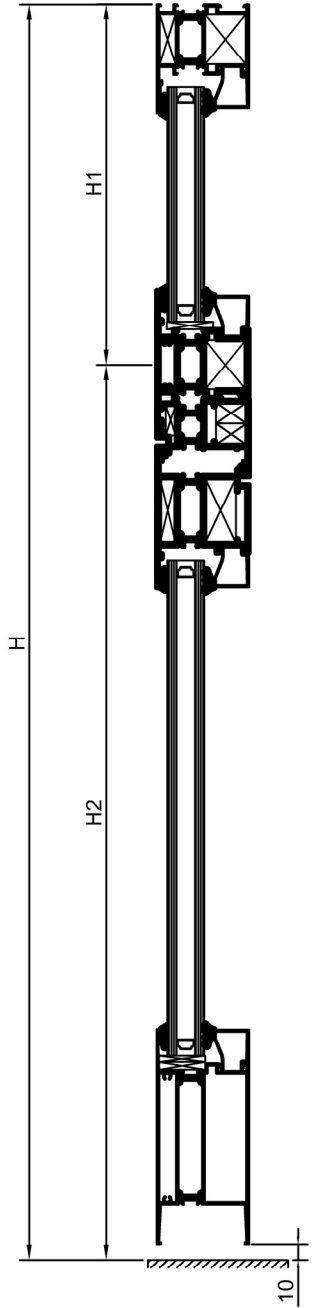

\*\* Not: Cam Çıtası Profillerinin ölçüleri preslenmiş kasa veya kanat üzerinden belirlenecektir.  
The measures of Glazing Bead will be determinate on pressed Frame and Vent.

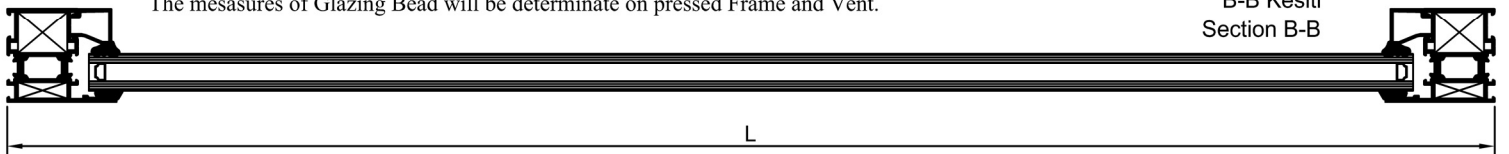

B-B Kesiti  
Section B-B

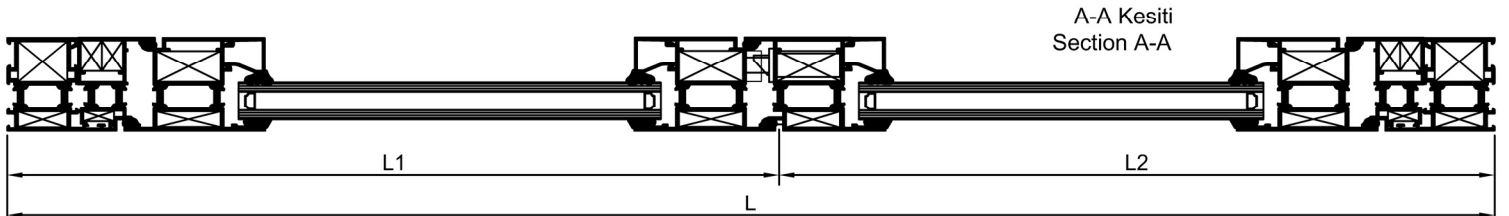

A-A Kesiti  
Section A-A

# ST 60

## Kesim Ölçüleri Cutting Measures

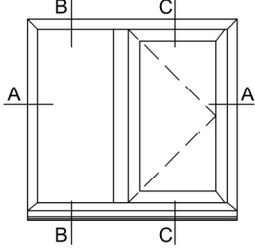

| Profilin adı<br>Profile Name                         | Kodu<br>Code | Sembol<br>Symbol | Adet<br>Quantity | Kesim<br>Cutting |
|--|--------------|------------------|------------------|------------------|
| Dar Kasa Profili<br>Frame Profile                    | 60ST10       |                  | 2                |                  |
|  |              |                  | 2                |                  |
| Dışa Açılır Pencere<br>Kanat Profili<br>Vent Profile | 60ST61       |                  | 2                |                  |
|  |              |                  | 2                |                  |
| Dar T Kasa Profili<br>Frame Profile                  | 60ST30       |                  | 1                |                  |
| Denizlik Profili<br>Sill profile                     | 60ST45       |                  | 1                |                  |
| Cam Çıtası Profili<br>Glazing Bead                   | 09-2997      |                  | 2                |                  |
|  |              |                  | 2                |                  |
|  |              |                  | 2                |                  |
|  |              |                  | 2                |                  |

\*\* Not: Cam Çıtası Profillerinin ölçüleri preslenmiş kasa veya kanat üzerinden belirlenecektir.  
The mesasures of Glazing Bead will be determinate on pressed Frame and Vent.

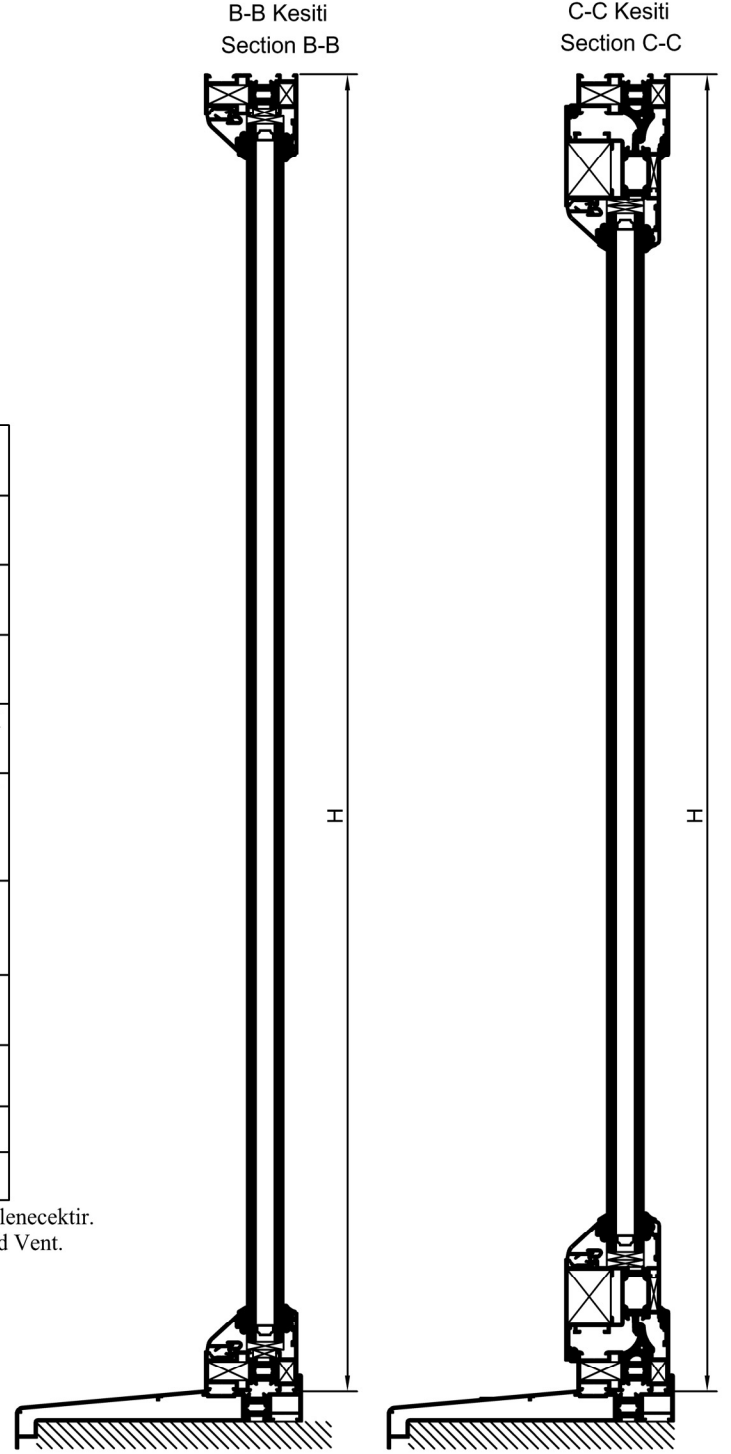
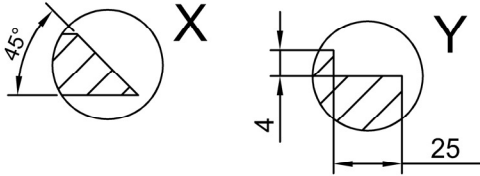

Ölçek : 1/5  
Scale : 1/5

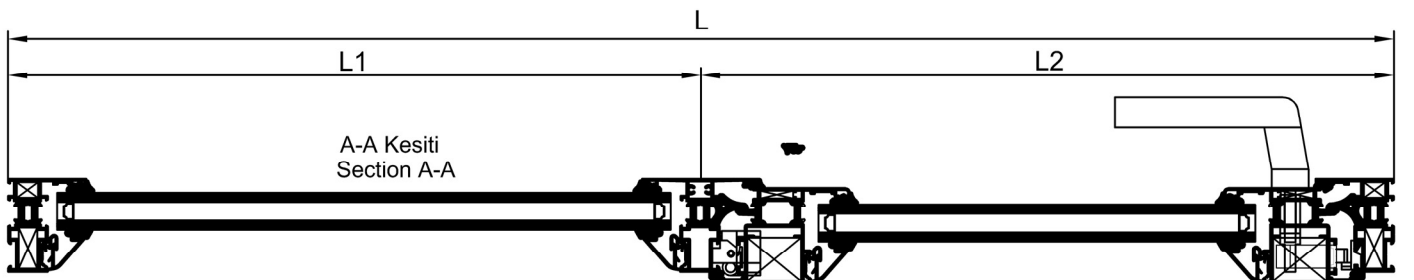

# ST 60

## Kesim Ölçüleri Cutting Measures

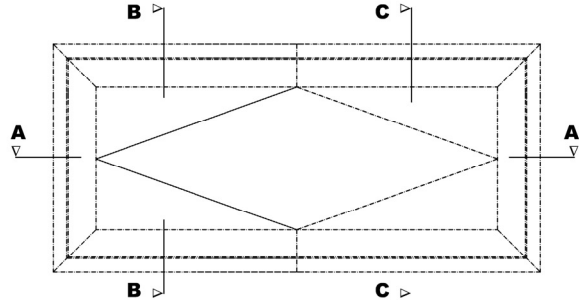

| Profilin adı<br>Profile Name       | Kodu<br>Code | Sembol<br>Symbol | Adet<br>Quantity | Kesim<br>Cutting   |
|------------------------------------|--------------|------------------|------------------|--------------------|
| Dar Kasa Profili<br>Frame Profile  | 60ST10       |                  | 2                | L                  |
|                                    |              |                  | 2                | H                  |
| Adaptör Profili<br>Vent Profile    | 60ST49       |                  | 2                | L <sub>1</sub> -22 |
|                                    |              |                  | 2                | L <sub>2</sub> -22 |
|                                    |              |                  | 2                | H-44.5             |
| Kanat Profili<br>Vent Profile      | 60ST26       |                  | 2                | L-111              |
|                                    |              |                  | 2                | H-111              |
| Cam Çıtası Profili<br>Glazing Bead | 3109         |                  | 2                | **                 |
|                                    |              |                  | 2                | **                 |

\*\* Not: Cam Çıtası Profillerinin ölçüleri preslenmiş kasa veya kanat üzerinden belirlenecektir.  
The mesasures of Glazing Bead will be determinate on pressed Frame and Vent.

Section B-B  
B-B Kesiti

Section C-C  
C-C Kesiti

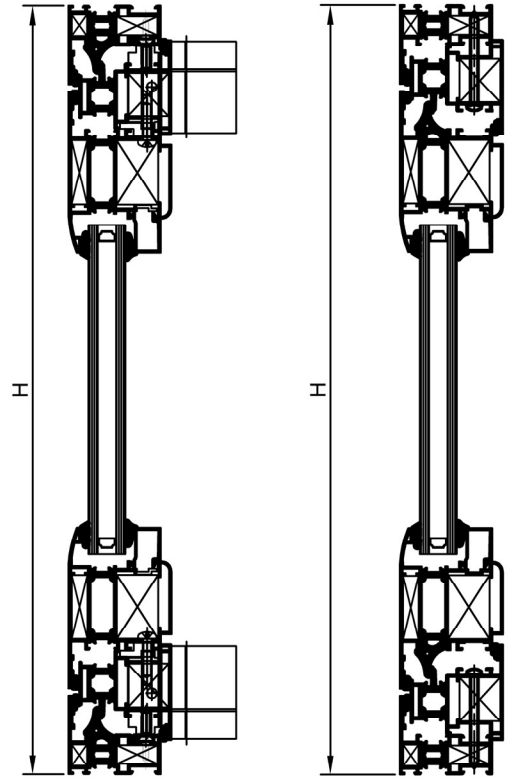

Ölçek : 1/5  
Scale : 1/5

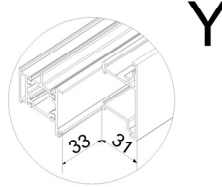
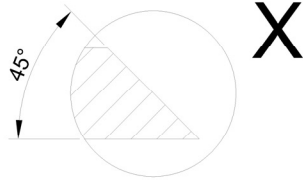

Section A-A  
A-A Kesiti

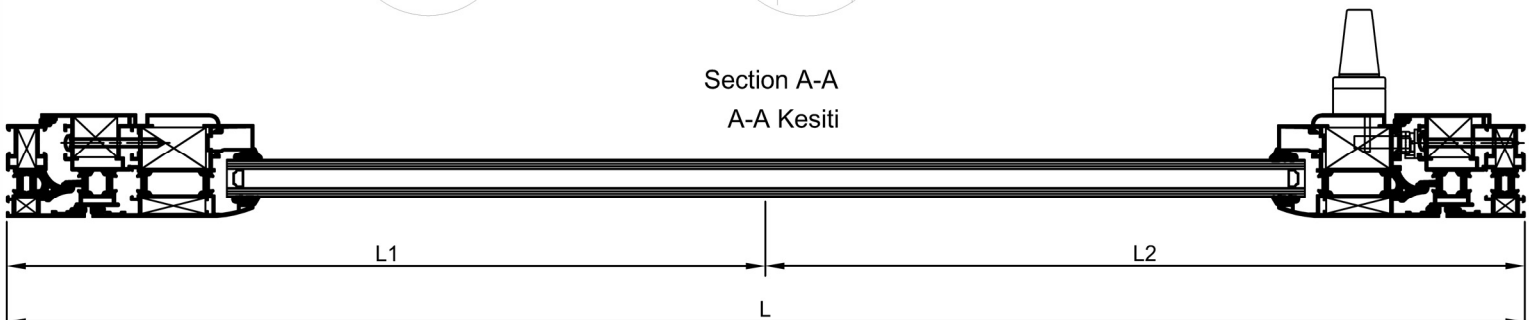

## Kesim Ölçüleri Cutting Measures

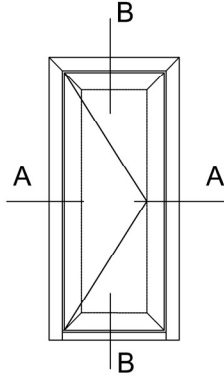

B-B Kesiti  
Section B-B

| Profilin adı<br>Profile Name       | Kodu<br>Code | Sembol<br>Symbol | Adet<br>Quantity | Kesim<br>Cutting |
|------------------------------------|--------------|------------------|------------------|------------------|
| Kasa Profili<br>Frame Profile      | 60ST12       |                  | 1                |                  |
|                                    |              |                  | 1                |                  |
| Kanat Profili<br>Vent Profile      | 60ST62       |                  | 1                |                  |
|                                    |              |                  | 1                |                  |
| Eşik Profili<br>Vent Profile       | 60ST75       |                  | 1                |                  |
| Cam Çıtası Profili<br>Glazing Bead | 3111         |                  | 2                |                  |
|                                    |              |                  | 2                |                  |

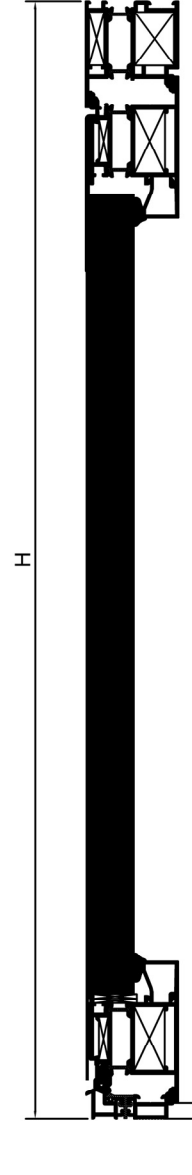
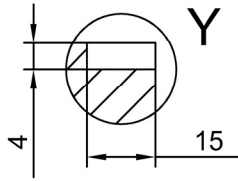
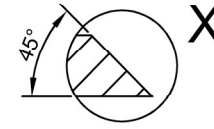

\*\* Not: Cam Çıtası Profillerinin ölçüleri preslenmiş kasa veya kanat üzerinden belirlenecektir.  
The mesasures of Glazing Bead will be determinate on pressed Frame and Vent.

Ölçek : 1/5  
Scale : 1/5

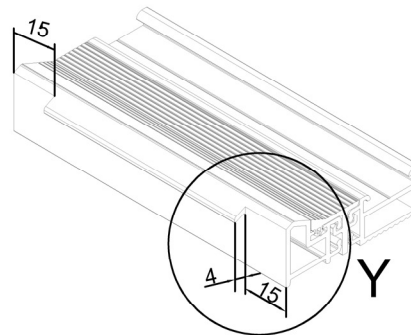

A-A Kesiti  
Section A-A

