

ST 70

Kesim Ölçüleri Cutting Measures

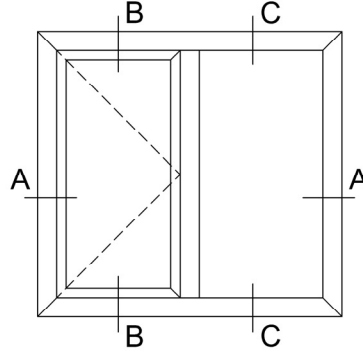

B-B Kesiti
Section B-B

C-C Kesiti
Section C-C

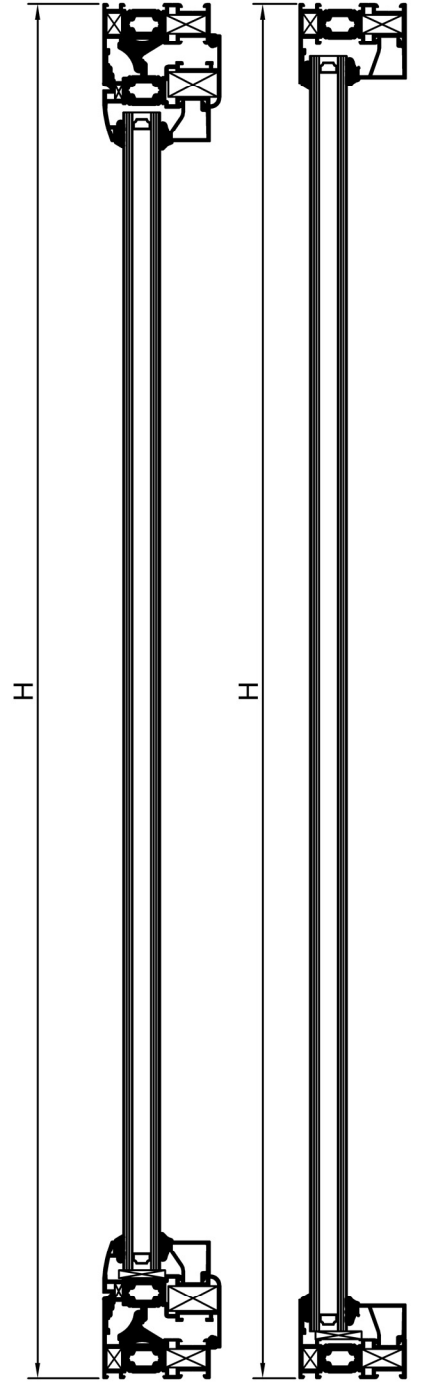

Profilin adı Profile Name	Kodu Code	Sembol Symbol	Adet Quantity	Kesim Cutting
Dar Kasa Profili Frame Profile	70ST10		2	
			2	
Dar Kanat Profili Vent Profile	70ST25		2	
			2	
Dar Orta Kayıt Profili Transom-Mullion Profile	70ST30		1	
Cam Çıtası Profili Glazing Bead	3112		2	
			2	
Cam Çıtası Profili Glazing Bead	3114		2	
			2	

** Not: Cam Çıtası Profillerinin ölçüleri preslenmiş kasa veya kanat üzerinden belirlenecektir.
The mesasures of Glazing Bead will be determinate on pressed Frame and Vent.

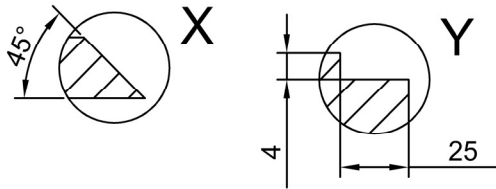

Ölçek : 1/5
Scale : 1/5

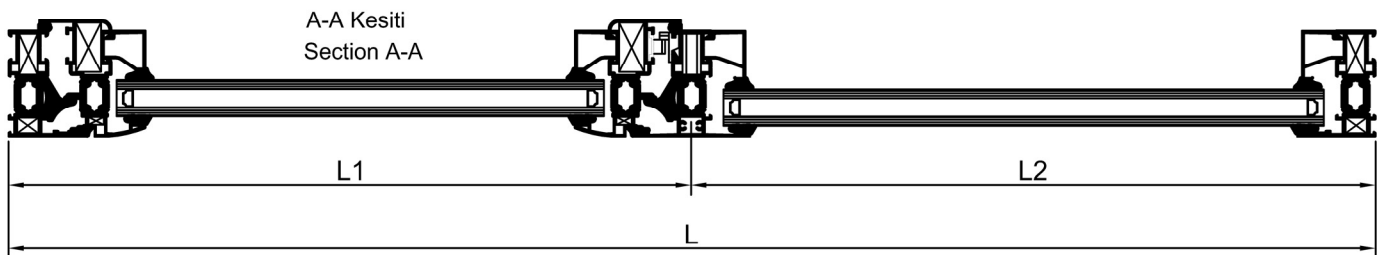

Kesim Ölçüleri Cutting Measures

Profilin adı Profile Name	Kodu Code	Sembol Symbol	Adet Quantity	Kesim Cutting
Geniş Kasa Profili Frame Profile	70ST11		1	L
			2	H
Kanat Profili Vent Profile	70ST24		1	L ₁ -78,5
			1	L ₂ -78,5
			3	H ₂ -63
Geniş Orta Kayıt Profili Transom-Mullion Profile	70ST31		1	L-92
Adaptör Profili Adapter Profile	70ST43		1	L-92
			2	H ₂ -33
Kanat Profili Vent Profile	70ST23		1	H ₂ -78
Etek Profili Bottom Rail Profile	70ST33		1	L ₁ -217
			1	L ₂ -192
Cam Çıtası Profili Glazing Bead	3114		2	**
			2	**
			2	**
			2	**
			4	**

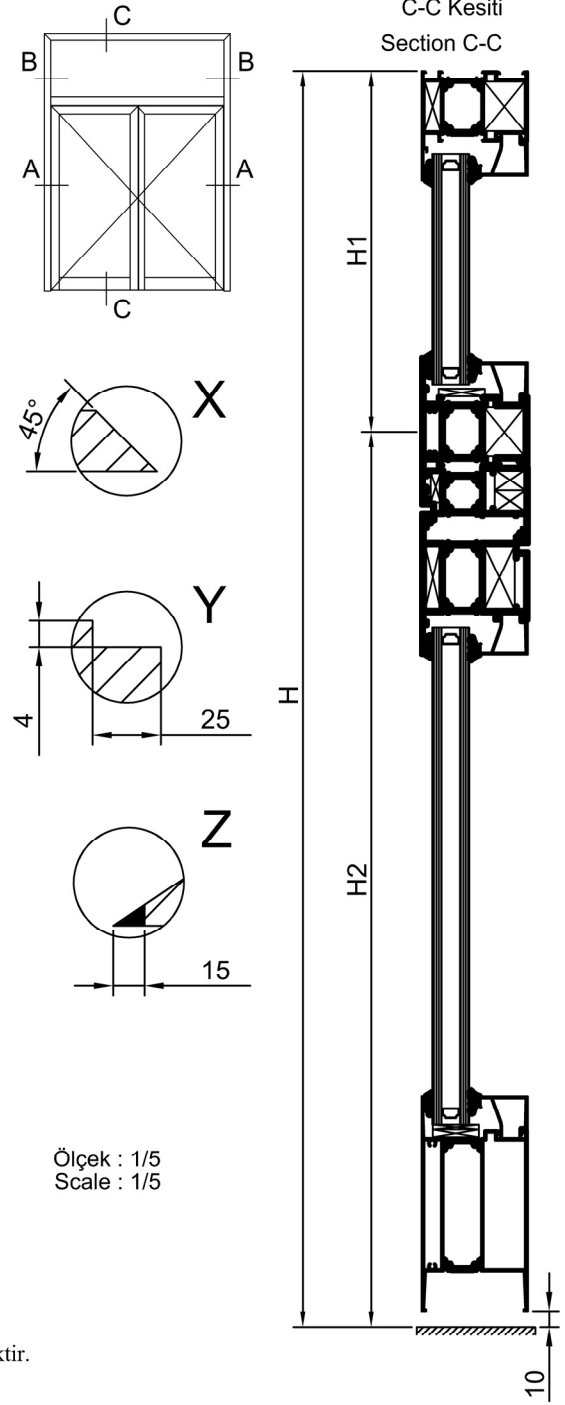

** Not: Cam Çıtası Profillerinin ölçüleri preslenmiş kasa veya kanat üzerinden belirlenecektir.
The mesasures of Glazing Bead will be determinate on pressed Frame and Vent.

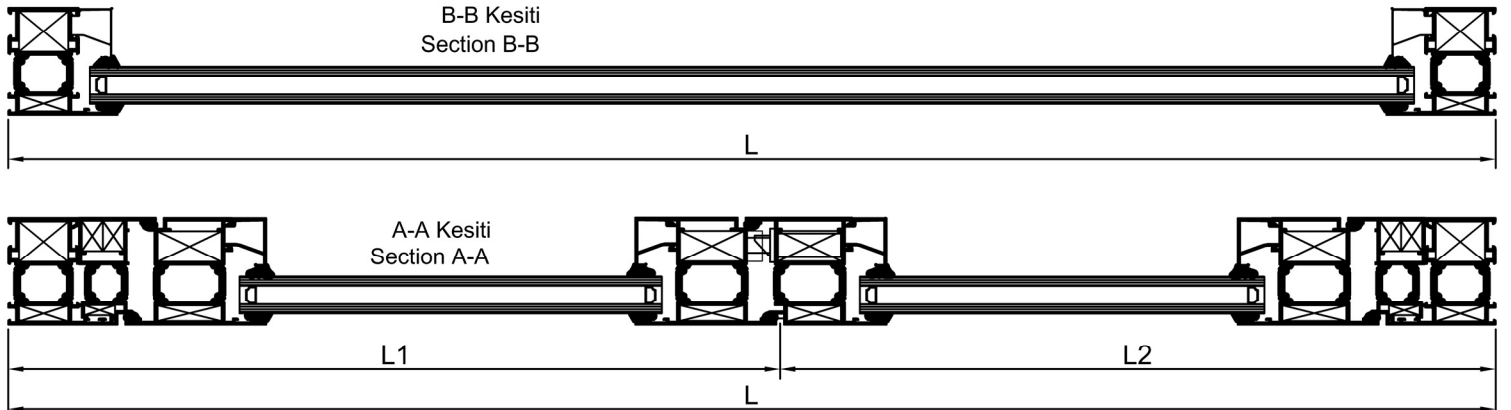

ST 70

Kesim Ölçüleri Cutting Measures

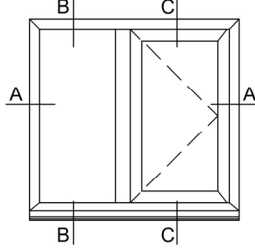

Profilin adı Profile Name	Kodu Code	Sembol Symbol	Adet Quantity	Kesim Cutting
Dar Kasa Profili Frame Profile	70ST10		2	
			2	
Dışa Açılır Pencere Kanat Profili Vent Profile	70ST61		2	
			2	
Dar T Kasa Profili Frame Profile	70ST30		1	
Denizlik Profili Sill profile	70ST45		1	
Cam Çıtası Profili Glazing Bead	08-2872		2	
			2	
			2	
			2	

** Not: Cam Çıtası Profillerinin ölçüleri preslenmiş kasa veya kanat üzerinden belirlenecektir.
The measures of Glazing Bead will be determined on pressed Frame and Vent.

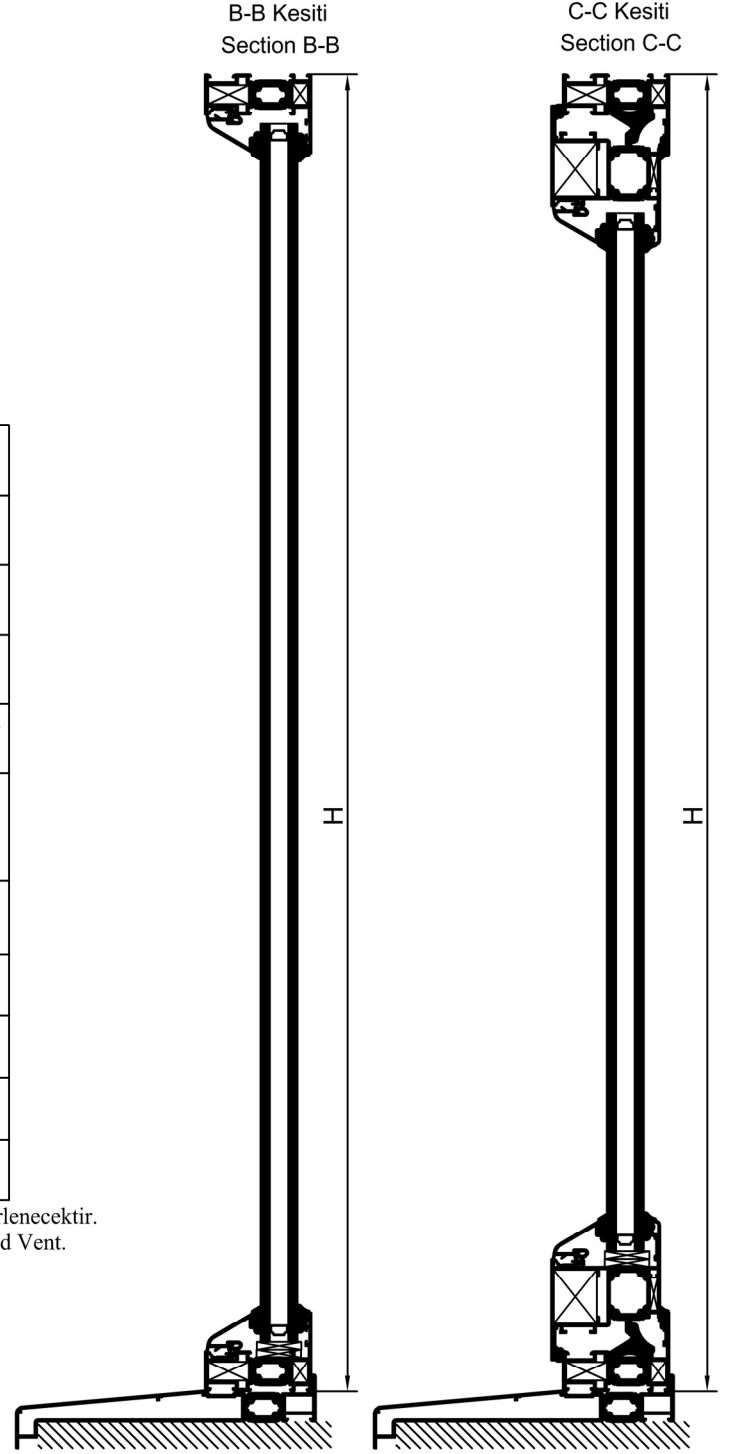
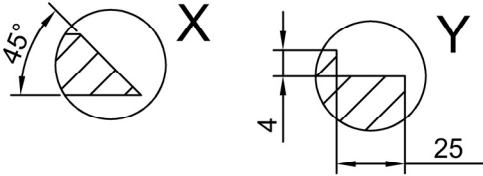

Ölçek : 1/5
Scale : 1/5

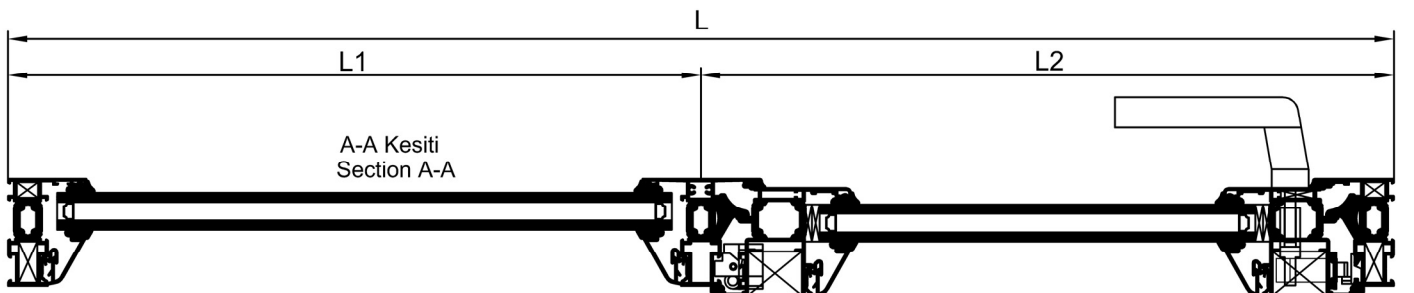

ST 70

Kesim Ölçüleri Cutting Measures

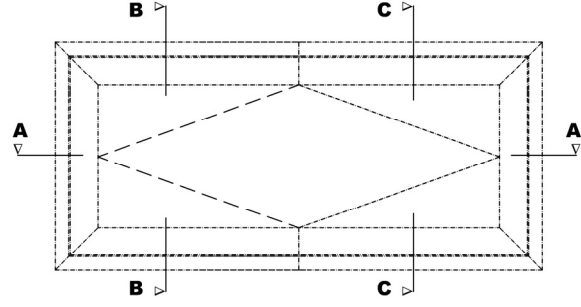

Profilin adı Profile Name	Kodu Code	Sembol Symbol	Adet Quantity	Kesim Cutting
Dar Kasa Profili Frame Profile	70ST10		2	L
			2	H
Adaptör Profili Vent Profile	70ST49		2	L ₁ -22
			2	L ₂ -22
			2	H-44.5
Kanat Profili Vent Profile	70ST26		2	L-111
			2	H-111
Cam Çıtası Profili Glazing Bead	3112		2	**
			2	**

** Not: Cam Çıtası Profillerinin ölçüleri preslenmiş kasa veya kanat üzerinden belirlenecektir.
The measures of Glazing Bead will be determinate on pressed Frame and Vent.

Section B-B
B-B Kesiti

Section C-C
C-C Kesiti

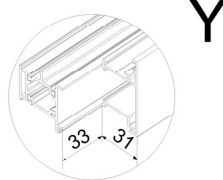
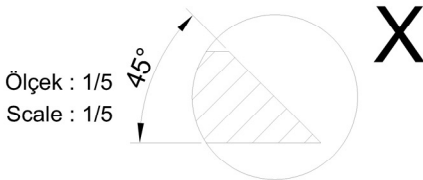
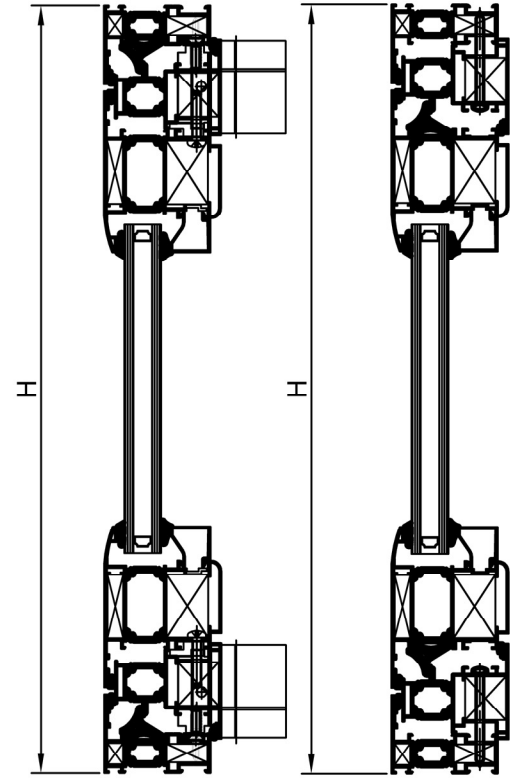

Section A-A
A-A Kesiti

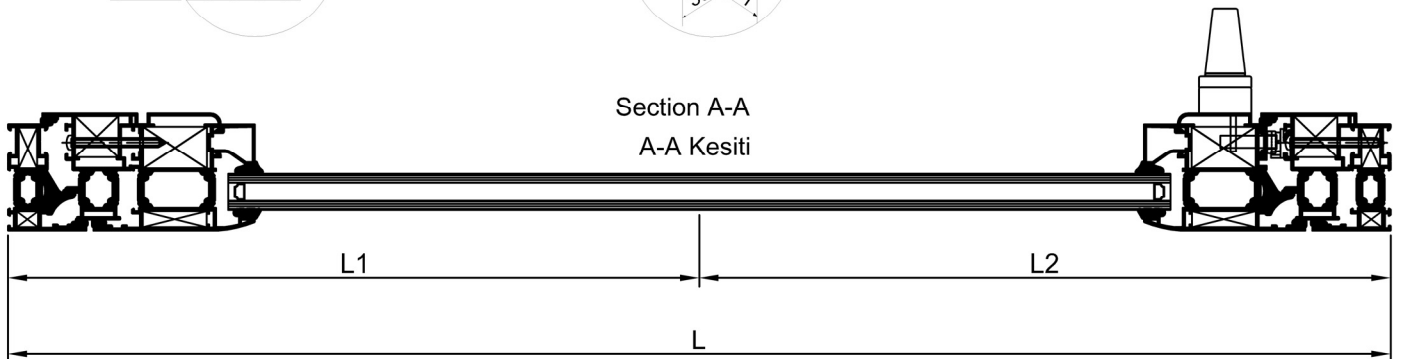

Kesim Ölçüleri Cutting Measures

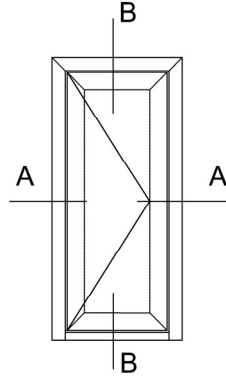

B-B Kesiti
Section B-B

Profilin adı Profile Name	Kodu Code	Sembol Symbol	Adet Quantity	Kesim Cutting
Kasa Profili Frame Profile	70ST12		1	
			1	
Kanat Profili Vent Profile	70ST62		1	
			1	
Eşik Profili Vent Profile	70ST75		1	
Cam Çıtası Profili Glazing Bead	3111		2	
			2	

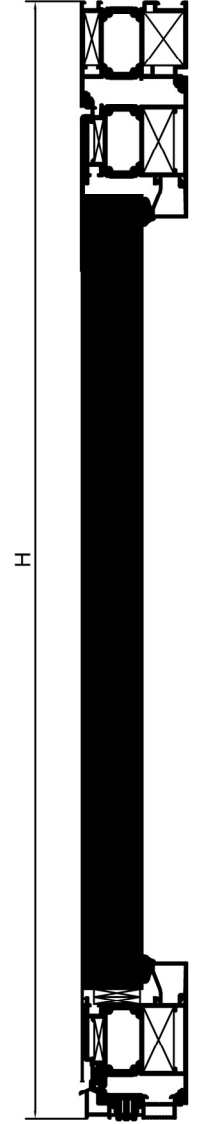
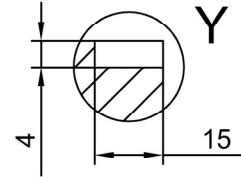
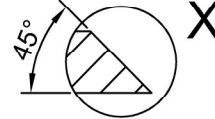

** Not: Cam Çıtası Profillerinin ölçüleri preslenmiş kasa veya kanat üzerinden belirlenecektir.
The measures of Glazing Bead will be determinate on pressed Frame and Vent.

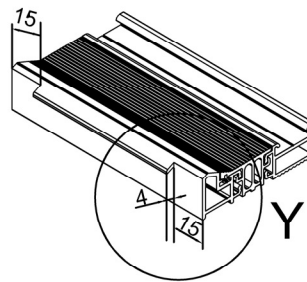

A-A Kesiti
Section A-A

Ölçek : 1/5
Scale : 1/5

